

L-121206
a b c d e f
2005

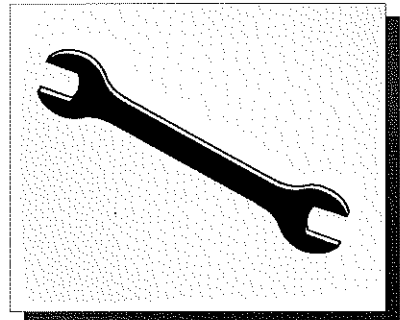

121206

ALKO

Garten + Hobby

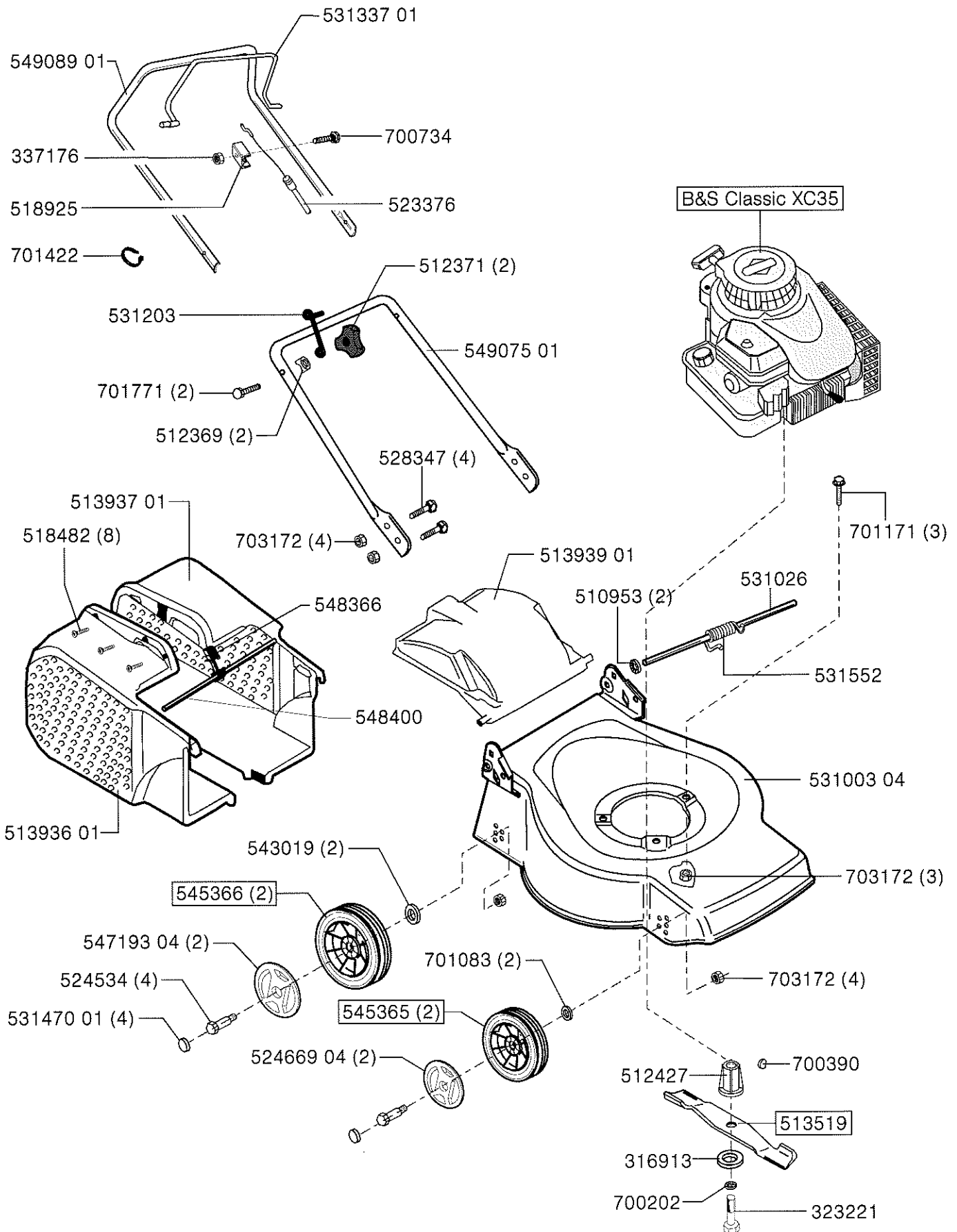



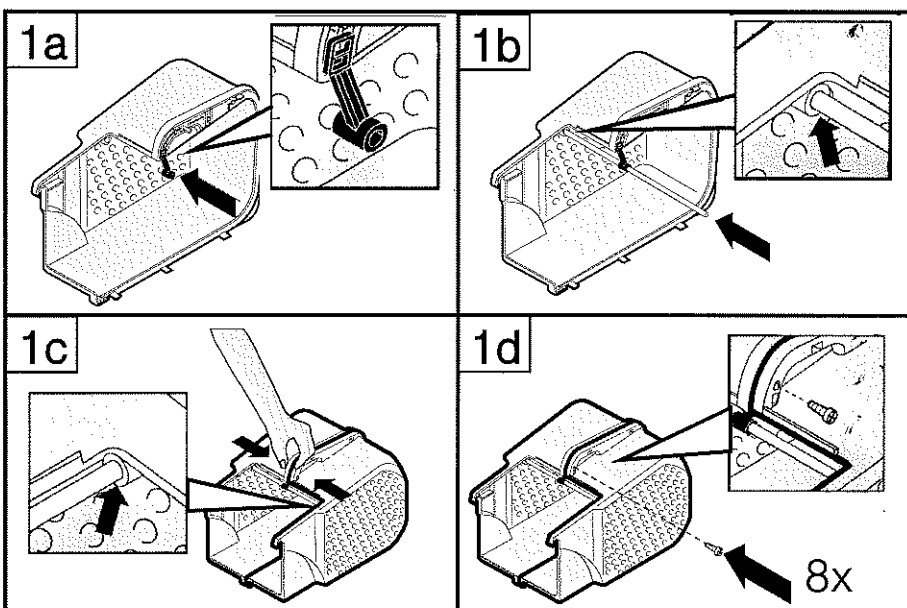
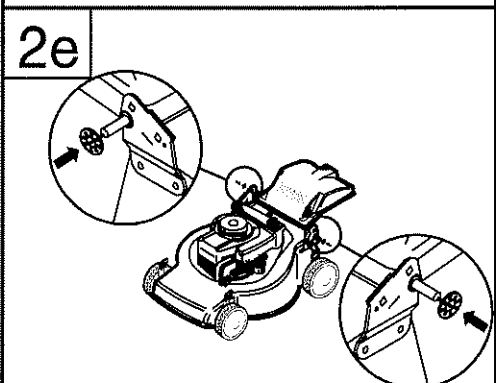
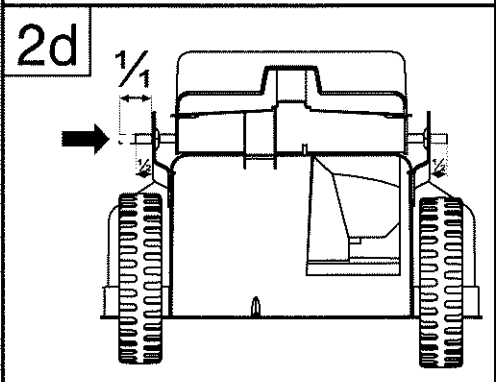
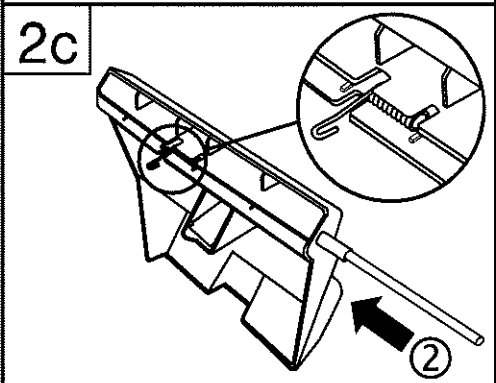
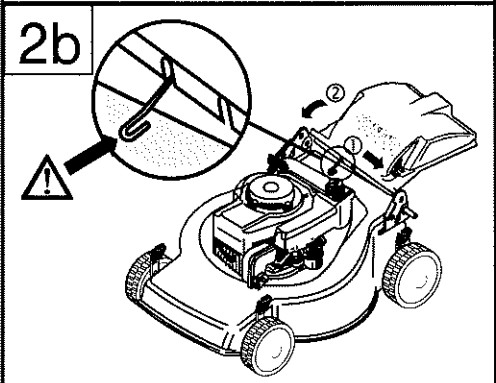
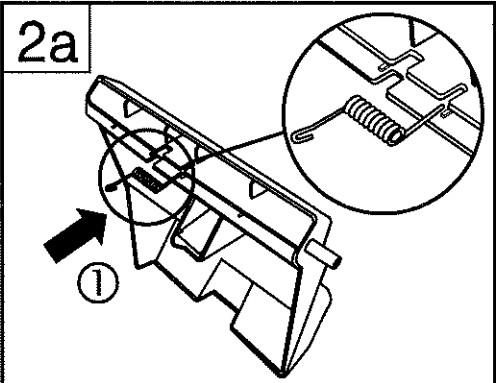
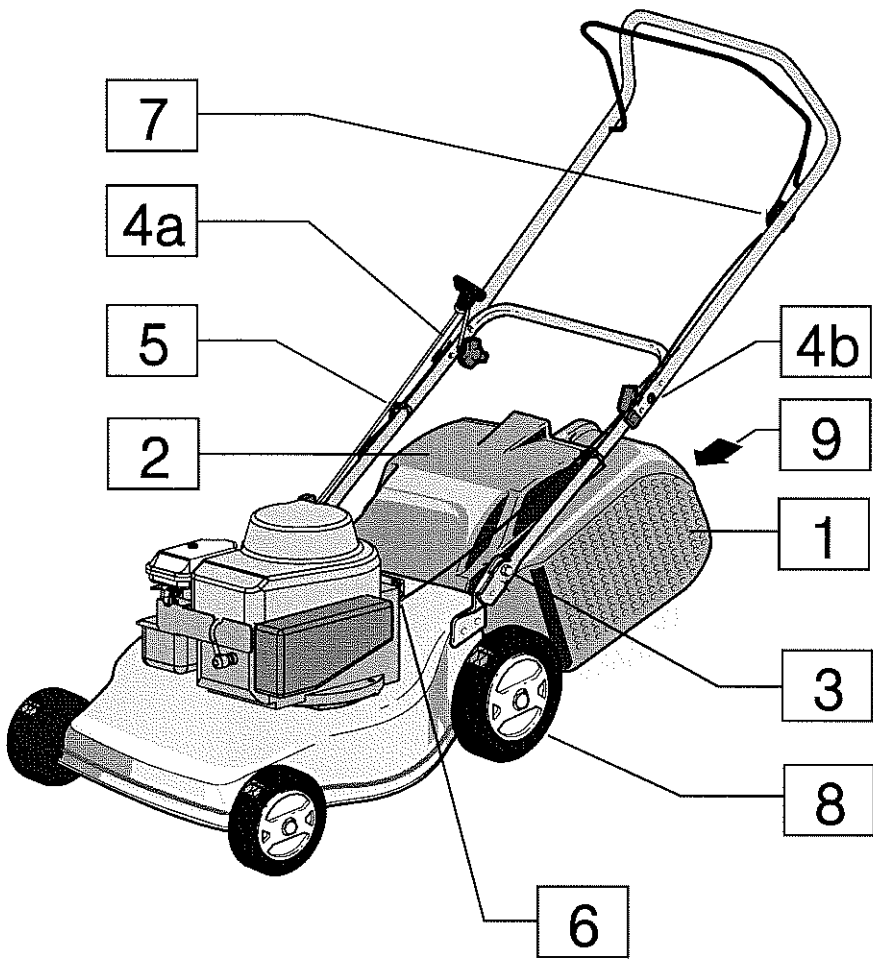

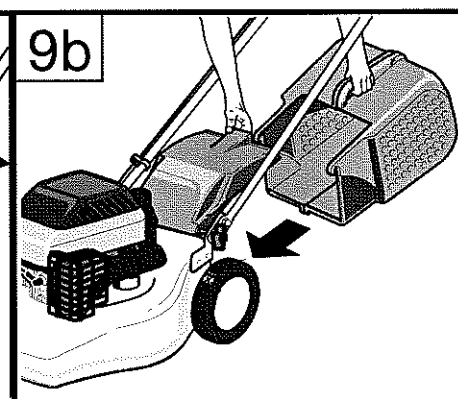
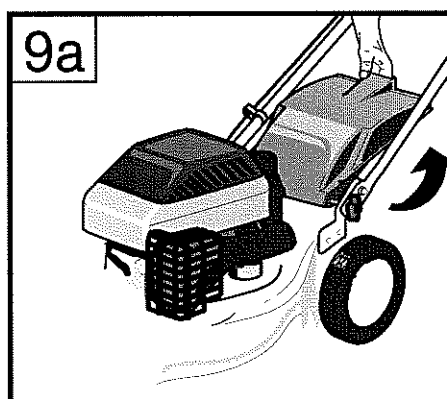
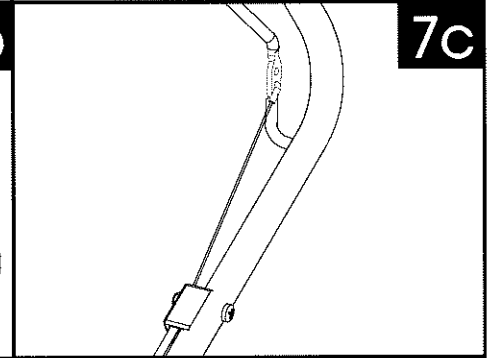
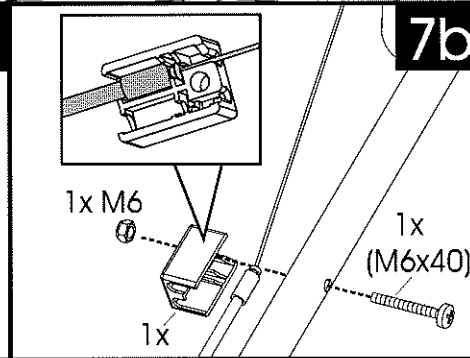
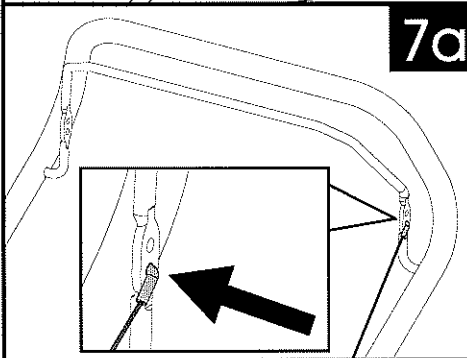
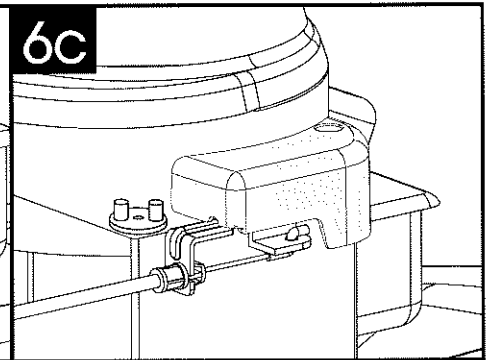
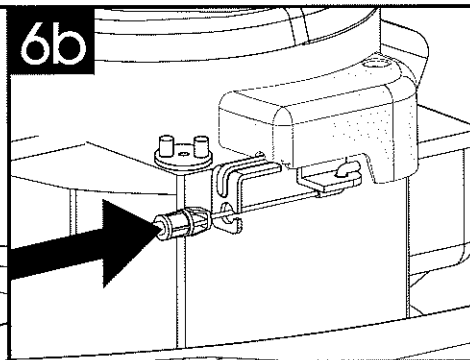
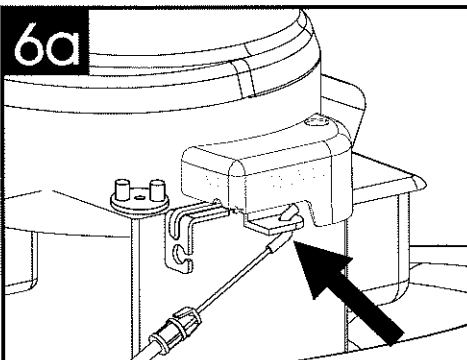
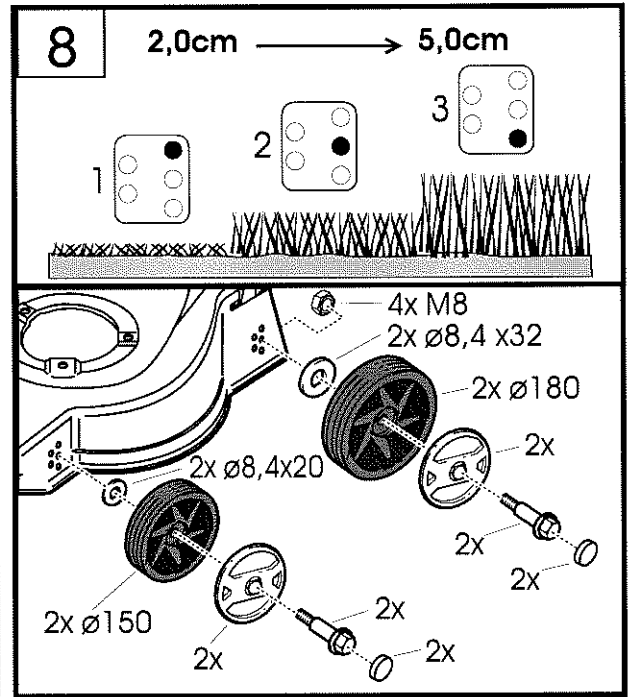
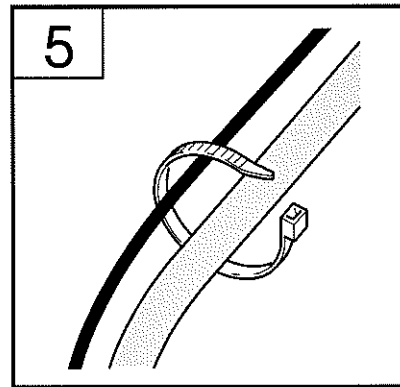
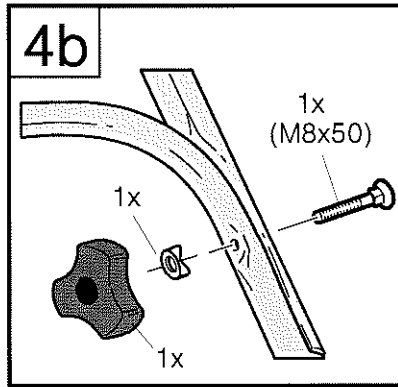
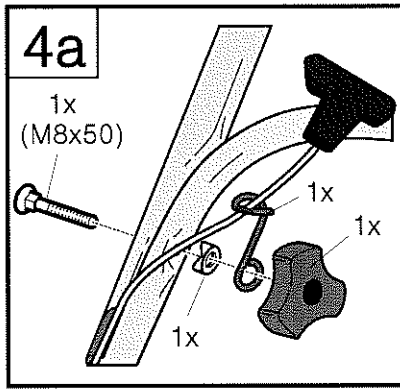
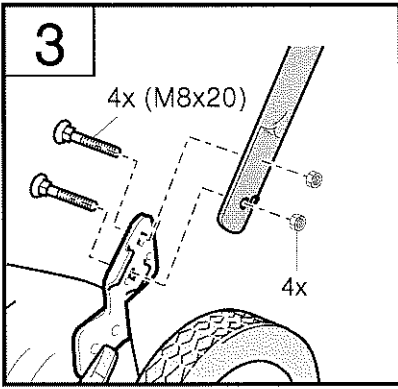

a (BP)	b	c	d	e	f
06/05					





EG-Konformitätserklärung	EC declaration of conformity	Déclaration de conformité CE	EC-verklaring van conformiteit	Dichiarazione di conformità CE	Declaración de conformidad de la CE
Wir	we	Nous	Wij	Noi	Nosotros
AL-KO Kober GmbH, A-8742 Werk Obdach / Steiermark					
erklären, dass die Maschine Rasenmäher, Typen:	declare that the machine lawnmowers, walk behind and mains-operated, Type:	déclarons que la machine Tondeuse à conducteur à pied commandées à la main Type :	verklaren dat de machine Grasmaaier, Type:	dichiariamo che la macchina Falciatrice, Tipo:	declaramos que la máquina Cortacésped, del tipo:
Classic 40 B					
mit den folgenden EG-Richtlinien übereinstimmen:	conforms to the specifications of the following EC directives:	est conforme aux spécifications des directives CE suivantes:	overeenstemt met de volgende CE-richtlijnen:	è conforme alle seguenti direttive CE:	cumple las siguientes directrices de la CE:
98/37/ EG • 89/336/EWG • 2000/14/EG					
gegebenenfalls angewendete Normen:	standards applied, if applicable:	Normes appliquées le cas échéant :	toegepaste normen, indien van toepassing	norme eventualmente applicate:	normas eventualmente aplicadas:
EN 836+A1+A2 • EN ISO 14982					
Gegebenenfalls Name und Anschrift der Person, die die technischen Unterlagen aufbewahrt/ If applicable, name and address of the person who keeps the technical documentation/ Le cas échéant, nom et adresse de la personne qui conserve la documentation technique/ Indien van toepassing naam en adres van de persoon die de technische documenten bewaart/ Eventualmente nome e indirizzo della persona che conserva la documentazione tecnica/ Eventualmente nombre y dirección de la persona que guarda la documentación técnica:					AL-KO Geräte GmbH Technische Entwicklung Geräte Ichenhauser Strasse 14 D-89359 Kötz
gewandtes Konformitätsbewertungsverfahren/ Conformity assessment procedure applied/ Sovellettu yhdenmukaisuuden toteamismenetelmä/ Procédure appliquée pour l'évaluation de la conformité/ Metodo di valutazione conformità applicato/ Procedimiento aplicado para la evaluación de conformidad.					Anhang VIII / Annex VIII / Annexe VIII/ Bijlage VIII / Appendice VIII / Anexo VIII
Gegebenenfalls Name und Anschrift der beteiligten benannten Stelle/ If applicable, name and address of the notified body involved/ Le cas échéant, nom et adresse de le bureau intéressé/ Tarvittaessa tarkastuspaikan nimi ja osoite/ indien van toepassing naam en adres van de deelnemende, aangewezen instelling/ Eventualmente nome e indirizzo dell'Ufficio interessato nominato/ Eventualmente nombre y dirección del organismo involucrado e indicado.					TÜV Product Service GmbH D-80339 München
Typen/ Type/ Tipo		40 B			
Schnittbreite/ Cutting width/ Largeur de coupe/ Maaibreedte/ Larghezza di taglio/ Ancho de corte		40 cm			
Gemessener Schalleistungspegel/ Measured sound power level/ Niveau de puissance acoustique mesuré/ Gemeten geluidsvermogen/ Livello di pressione acustica misurato/ Nivel de potencia acústica medido	L _{WA}	95 dB(A)			
Garantierter Schalleistungspegel/ Guaranteed sound power level/ Niveau de puissance acoustique garanti/ Gegarandeerd geluidsvermogen/ Livello di pressione acustica garantito/ Nivel de potencia acústica garantizado	L _{WA}	96 dB(A)			

EF- Overensstemmelseserklæring	EG- konformitetsförläring	EF- Konformitetserklæring	EU- yhdenmukaisuusilmoitus		
Vi	Vi	Vi	Me		
AL-KO Kober GmbH, A-8742 Werk Obdach / Steiermark					
erklærer, at maskinen Plæneklipper, Type:	förklarar, att denna maskin Gräsklippare typ:	erklærer at maskinen plenklipper, Type:	ilmoittamme, että kone Ruohonleikkuri, Tyyppi:		
Classic 40 B					
stemmer over ens med følgende EF-direktiver:	stämmer överens med följande EG-direktiv:	er i samsvar med følgende EF-direktiver:	vastaa seuraavia EU- direktiiveja		
98/37/ EG • 89/336/EWG • 2000/14/EG					
I givet fald anvendte normer:	Tillämpade normer:	Standarder som eventuelt anvendes:	Tarvittaessa sovelletut normit:		
EN 836+A1+A2 • EN ISO 14982					
I givet fald navn og adresse på personen, der opbevarer den tekniske dokumentation/ Om tillämpligt namn och adress på den person som förvarar den tekniska dokumentationen/ Eventuelt navn og adresse til personen som oppbevarer teknisk dokumentasjon/ Tarvittaessa sen henkilön nimi ja osoite, joka säilyttää teknisiä asiakirjoja					AL-KO Geräte GmbH Technische Entwicklung Geräte Ichenhauser Strasse 14 D-89359 Kötz
Anvendt overensstemmelses-vurderingsproces/ Tillämpade konformitetsbedömningsrutiner/ Benyttet konformitetsvurderingsprosedyre/ Sovellettu yhdenmukaisuuden toteamismenetelmä					Anhang VIII / Annex VIII / Annexe VIII/ Bijlage VIII / Appendice VIII / Anexo VIII
Tarvittaessa tarkastuspaikan nimi ja osoite Om tillämpligt namn och adress på respektive institution/organ/ Eventuelt navn og adresse til den underrettende myndighet/ Tarvittaessa tarkastuspaikan nimi ja osoite					TÜV Product Service GmbH D-80339 München
Typen/Type/ typ/ Tyyppi		40 B			
snitbredde/ snittbredd/ Klippebredde/ Leikkausleveys		40 cm			
Målt lydniveau/ Uppmått ljudeffektnivå/ Målt støyeffektnivå/ Mitattu melutaso	L _{WA}	95 dB(A)			
Garanteret lydniveau/ Garanterad ljudeffektnivå/ Garantert støyeffektnivå/ Taattu melutaso	L _{WA}	96 dB(A)			

 i	
Type :	40 B
	1310 x 1020 x 450
cm	
	40 cm
	23,5
	2,5 – 6,5 cm
	65 L.
	EN 1033 a_{vhw}= 12 m/s²

Obdach, 21.11.2005

Ing. Rainer Klaus

Geschäftsleiter / Director / Directeur

Ort/Place / Lieu / Plaats / Località / Localidad / Helyiség
/ Misto / Miesto / Miejscowość / LocalUnterschrift / Signature / Handtekening / Firma / Aláírás
/ Podpis / AssinaturaBeauftragter / Representative / Délégué / Gemachtigd /
Responsable / Delegado / Meghatalmazott / Představitel
Zodpovedný / Zlecenioborca / Encarregado 2)

- ilt nur für Rasenmäher, Rasentrimmer und Rasenkantentrimmer / Valid only for Lawnmowers, lawn trimmers and lawn edge trimmers / Être valable pour tondeuse, coupe-gazon et coupe-bordures.
- Angaben zum Unterzeichner, der bevollmächtigt ist, die Erklärung für den Hersteller oder seinen in der Gemeinschaft niedergelassenen Bevollmächtigten rechtsverbindlich zu unterzeichnen.
Identification of the person empowered to sign on behalf of the manufacturer or his authorized representative established in the community.
Identification du signataire ayant reçu pouvoir pour engager le fabricant ou son mandataire établi dans la communauté.

Land	Firma	Tel	Fax
A	AL-KO Kober Ges.m.b.H.	(+43) 3578/2515227	(+43) 3578/251538
AUS	AL-KO International PTY. LTD	(+61) 3/9767-3700	(+61) 3/9767-3799
B	Eurogarden NV	(+32) 16/805427	(+32) 16/805425
CH	AL-KO Kober AG	(+41) 56/4183150	(+41) 56/4183160
CZ	AL-KO Kober Spol.sr.o.	(+420) 382/210381	(+420) 382/212782
D	AL-KO Geräte GmbH	(+49) 8221/203-0	(+49) 8221/203-138
DK	AL-KO Ginge A/S	(+45) 98/82-1000	(+45) 98/82-5454
E	ANMI	(+34) 93/3002618	(+34) 93/3001769
F	AL-KO S.A.S.	(+33) 3/85-763540	(+33) 3/85-763588
GB	Rochford Garden Machinery Ltd.	(+44) 1963/828050	(+44) 1963/828052
H	AL-KO KFT	(+36) 29/537050	(+36) 29/537051
I	AL-KO Kober GmbH / SRL	(+39) 039/9 329311	(+39) 039/9329390
LV	AL-KO Kober SIA	(+371) 7/409330	(+371) 7807018
N	AL-KO GINGE A/S	(+47) 64/862550	(+47) 64/862554
NL	Mechatechnik B.V.	(+31) 18/2567824	(+31) 18/2533895
PL	AL-KO Kober z.o.o.	(+48) 61/8161925	(+48) 61/8161980
RUS	OOO AL-KO Kober	(+7) 095/1688716	(+7) 095/1623238
RUS	AL-KO St. Petersburg GmbH	(+7) 812/4461084	(+7) 812/4461084
S	AL-KO Ginge Svenska AB	(+46) 31/573580	(+46) 31/575620
SK	AL-KO Kober Slovakia Spol.s.r.o.	(+421) 2/45994112	(+421) 2/45648117
SLO	Merkur d.d.	(+386) 42588290	(+386) 42588805
UA	TOV AL-KO Kober	(+380) 44/4536163	(+380) 44/4536162

Stand 11/2005

AL-KO Geraete GmbH
Head Quarter
Ichenhauser Str. 14
89359 Koetz
Telefon: (+49)8221/203-0
Telefax: (+49)8221/203-138
www.al-ko.com